

DUCTILE IRON GATE VALVE FLANGED PN16 DIN3202-1 F4 STAINLESS STEEL SEAT

Ductile iron gate valve with stainless steel seat flanged PN10/16 full bore for opening/closing networks of water, water treatment and heating.

Outside screw stem, rising stem and non rising handwheel.

Graphite packing and bonnet gasket.

Certificate

3.1



Lloyd's
Register
PED/2014/68/UE



Size : DN50 to DN300

Connection: Flanges RF PN10/16

Min Temperature : -10°C

Max Temperature : +180°C

Max Pressure : 16 Bars

Specifications : Rising stem and non rising handwheel

Stainless steel stem and seat

Outside screw stem

Full bore

Materials : Ductile iron body EN GJS-500-7

DUCTILE IRON GATE VALVE FLANGED PN16 DIN3202-1 F4 STAINLESS STEEL SEAT

SPECIFICATIONS :

- Single solid wedge
- Oblique seat
- Graphite packing
- Full bore
- Rising stem and non rising handwheel
- Stainless steel stem
- Stainless steel seat
- Flanges R.F. PN16
- Alkyde painting RAL 7011 grey color, 90 µm thickness for body
- Painting RAL 6032 green color for handwheel

USE :

- For water, water treatment, heating
- Min and max Temperature Ts : - 10°C to + 180°C
- Max Pressure Ps : 16 bars

RANGE :

- Ductile iron body flanged R.F. PN16 Ref. 159 from DN 40 to DN 300

TORQUE VALUES (Nm without safety coefficient) :

DN	40	50	65	80	100	125	150	200	250	300
Torque (Nm)	55	55	55	60	85	115	125	135	192	192

LEAKAGE RATE (WITH WATER AT 20°C) :

DN	Leakage rate (mm ³ /s)
40	0.4
50	0.5
65	0.65
80	0.80
100	1.00
125	1.25
150	1.50
200	2.00
250	2.50
300	3.00

NUMBER OF CYCLES TO CLOSE OR OPEN THE VALVE :

DN	40	50	65	80	100	125	150	200	250	300
Number of cycles	13	15.5	19.3	23.5	29	35.3	33.3	43.6	53.6	65

DUCTILE IRON GATE VALVE FLANGED PN16 DIN3202-1 F4 STAINLESS STEEL SEAT

HEADLOSS GRAPH:

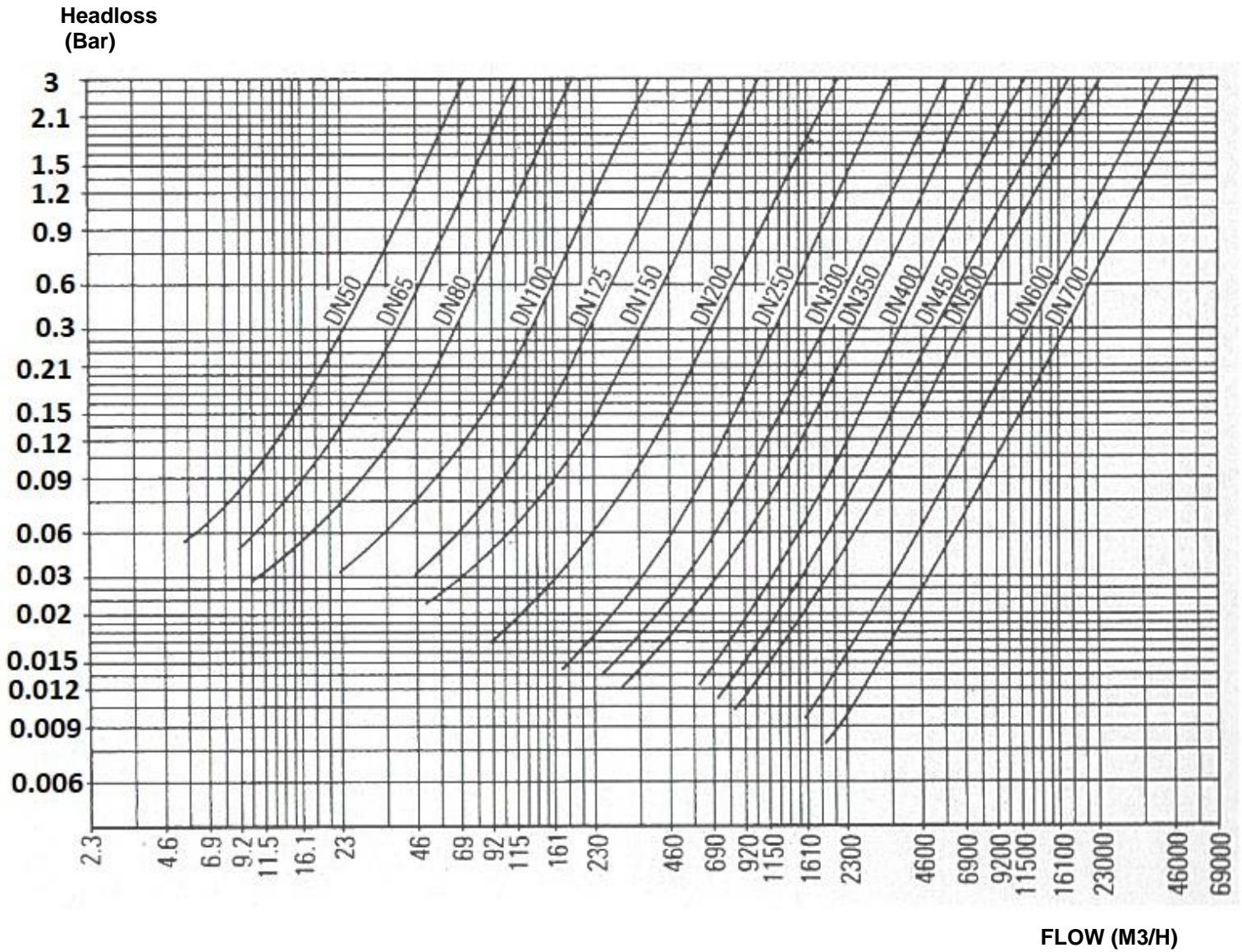

DUCTILE IRON GATE VALVE FLANGED PN16 DIN3202-1 F4 STAINLESS STEEL SEAT

PRESSURE / TEMPERATURE GRAPH (STEAM EXCLUDED) :

Pressure (Bar)

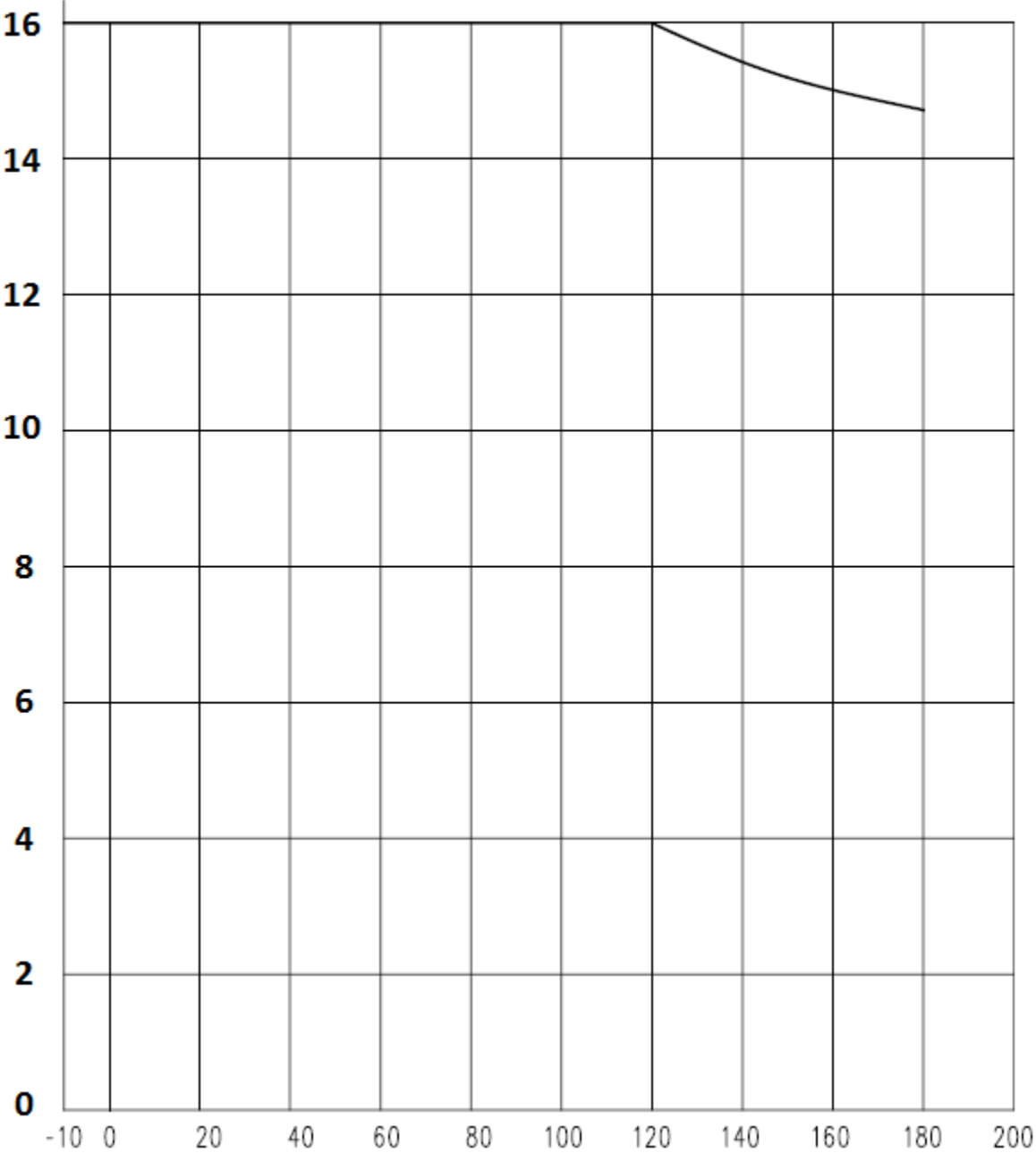

Temperature (°C)

DUCTILE IRON GATE VALVE FLANGED PN16 DIN3202-1 F4 STAINLESS STEEL SEAT

MATERIALS :

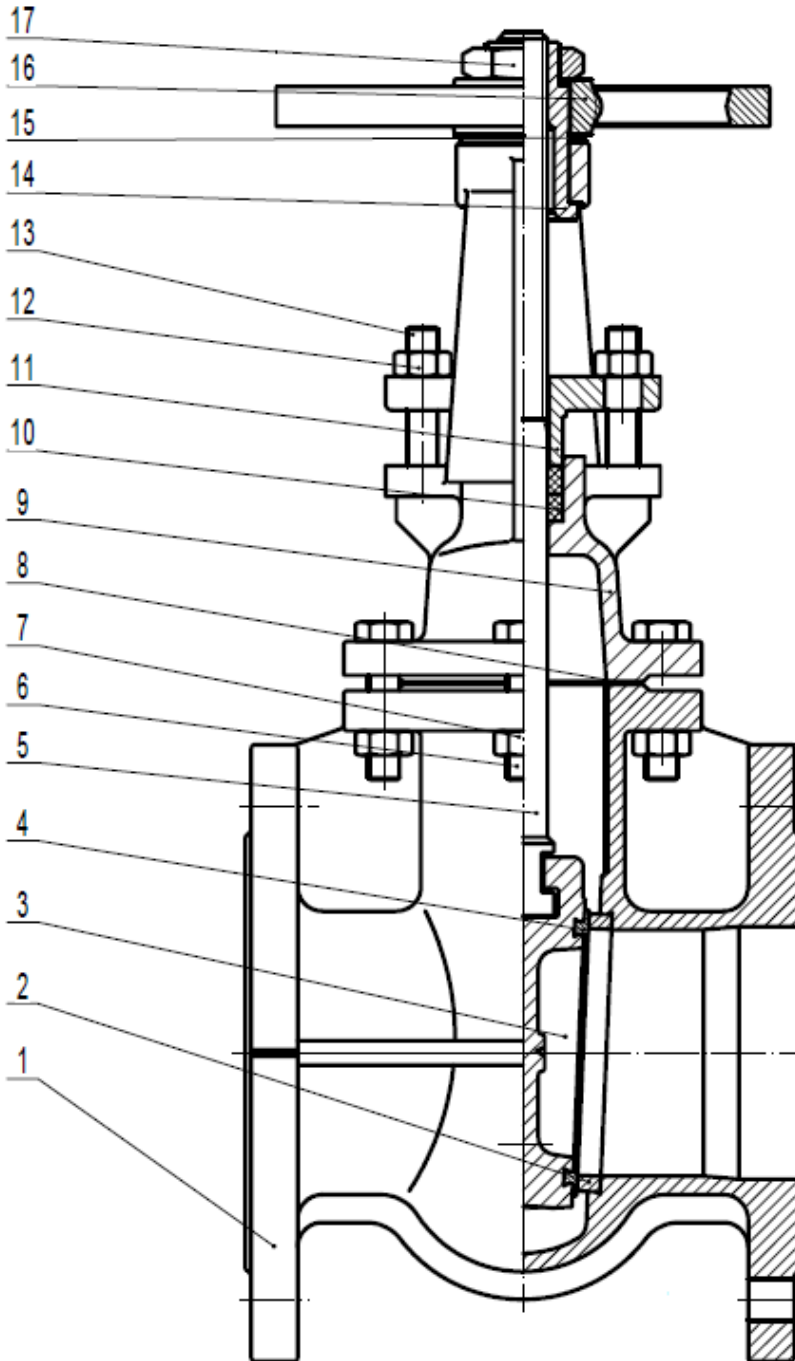

Item	Designation	Materials
1	Body	Ductile iron EN-GJS-500-7
2	Body seat	AISI 304
3	Wedge	Ductile iron EN-GJS-500-7
4	Wedge seat	AISI 304
5	Stem	AISI 420
6	Screw	Steel RSt37-2 (1.0038)
7	Nut	Steel RSt37-2 (1.0038)
8	Bonnet gasket	Graphite
9	Bonnet	Ductile iron EN-GJS-500-7
10	Packing	Graphite
11	Packing gland	Ductile iron EN-GJS-500-7
12	Nut	Steel RSt37-2 (1.0038)
13	Screw	Steel RSt37-2 (1.0038)
14	Stem nut	Brass
15	Washer	Brass
16	Handwheel	Cast iron EN GJL-250
17	Handwheel nut	Ductile iron EN GJS-500-7

DUCTILE IRON GATE VALVE FLANGED PN16 DIN3202-1 F4 STAINLESS STEEL SEAT

SIZE (in mm) :

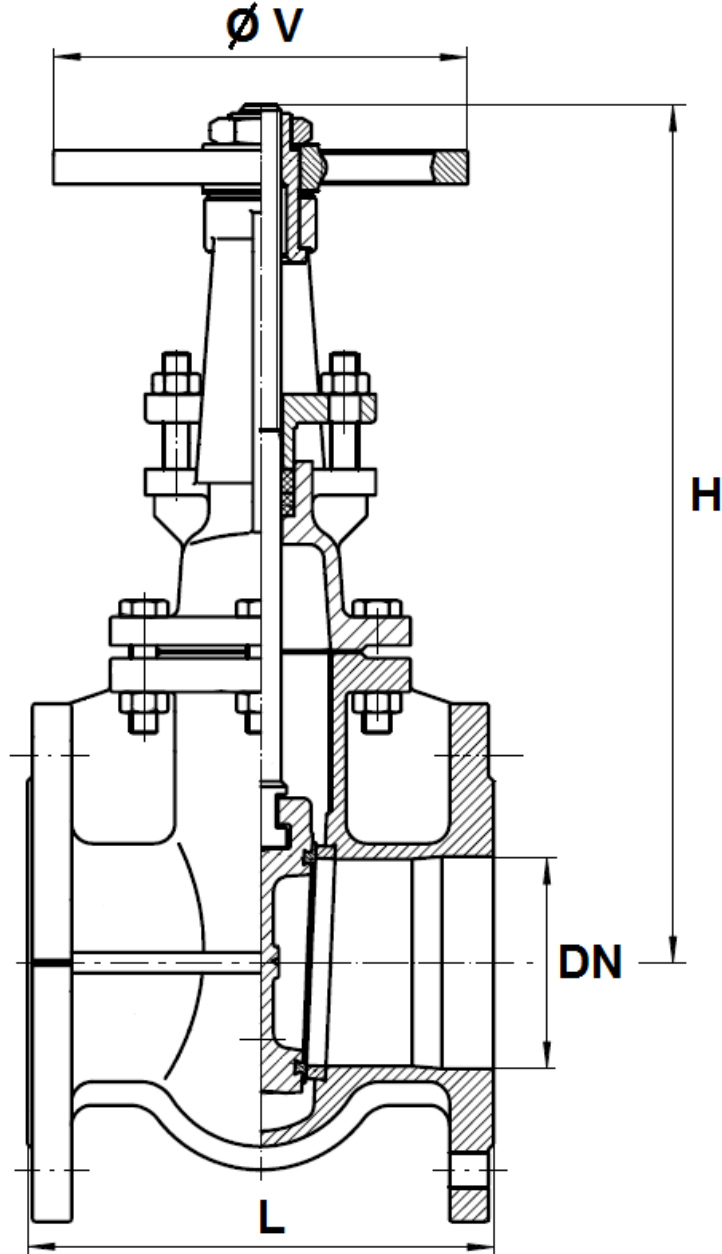

DN	40	50	65	80	100	125	150	200	250	300
L	140	150	170	180	190	200	210	230	250	270
H (closed)	244	254	294	331	385	457	545	683	823	952
H (opened)	295	315	371	424	500	598	711	901	1093	1273
Ø V	160	160	160	160	200	200	250	250	320	320
Weight (Kg)	9.8	11.9	13.3	17.2	23.2	34.2	47	67.5	110	170
Ref.	159040	159050	159065	159080	159100	159125	159150	159200	159250	159300

DUCTILE IRON GATE VALVE FLANGED PN16 DIN3202-1 F4 STAINLESS STEEL SEAT

FLANGES SIZE (in mm) :

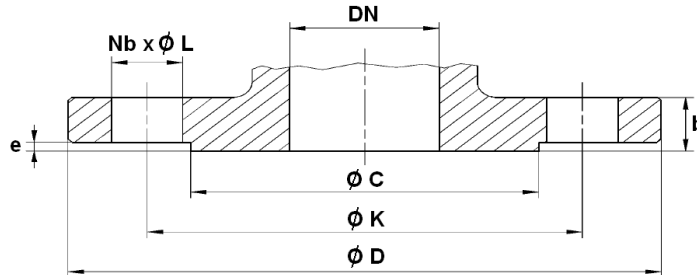

PN	PN10/16							PN16		
DN	40	50	65	80	100	125	150	200	250	300
Ø C	80	102	124	140	158	188	212	268	320	378
Ø D	150	165	185	200	220	250	285	340	405	460
Ø K	110	125	145	160	180	210	240	295	355	410
Nb x Ø L	4 x 19	4 x 19	4 x 19	8 x 19	8 x 19	8 x 19	8 x 23	12 x 23	12 x 28	12 x 28
b	16	16	16	17	17	18	20	21	23	24
e	2	2	2	2	2	3	3	3	3	4

STANDARDS :

- Manufacturer certified ISO 9001 : 2015
- DIRECTIVE 2014/68/EU : CE N° 0038
Risk category III module H
- Certificate 3.1 on request
- Pressure tests according to EN 12266-1, leakage rate B
- Length according to EN 558 series 14 (DIN 3202-1 F4)
- Flanged R.F. according to EN 1092-2 PN16
- Design according to DIN 3352