

## FBB Series Flowmeters

Diaphragm-type flowmeters with calibrated flange, with offtake flowmeter for large flow rates.

### APPLICATIONS

Flowmeter can be used in the following industries: chemicals and petrochemicals, pulp and paper, food and sugar, pharmaceuticals, glass, textile, mining, metallurgical and galvanizing industry.

The instruments can also be used by manufacturers of water treatment plants, wine, thermal, hospital and anti-pollution plants, **firefighting pressurization units**, etc.

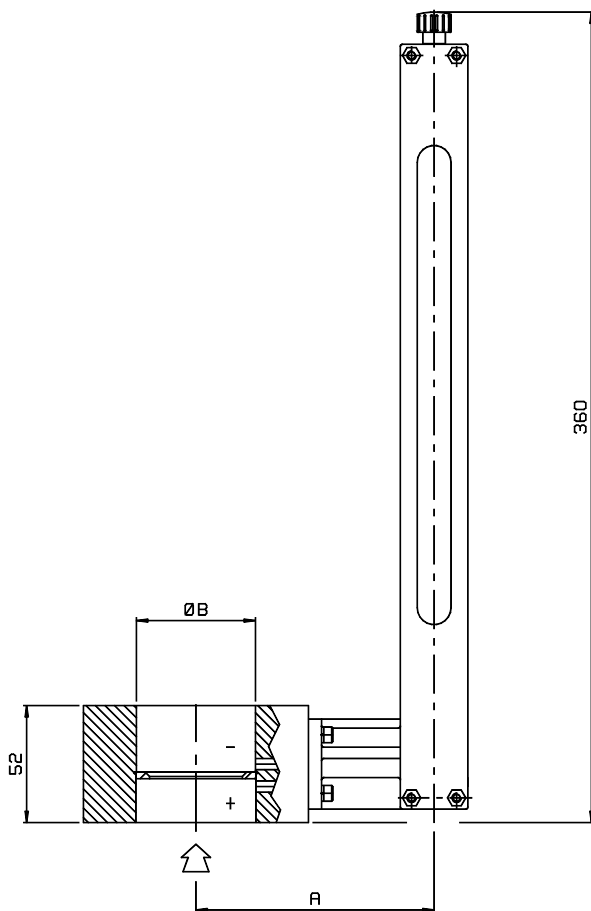

### TECHNICAL DATA

- Performance in compliance with the EN12845. (Fire extinction equipment)
- Max. pressure: 16 bar
- Max. temperature: 100°C
- Length of reading scale: ~200mm
- Measurement range: ~1:10
- Guided float
- Suitable for insertion in flanges: UNI PN10/16; ANSI 150
- The lateral buttonholes allow the spin of the glass tube, therefore one visibility of 360° of the graduate scale

MOD.	A mm	ØB mm	WEIGHT Kg
40	115	41.9	0.5
50	125	53.1	0.5
65	135	70.9	0.7
80	140	83.1	1
100	155	107.9	1.5
125	170	132.5	9
150	180	160.3	11
200	210	209.1	15
250	240	260.3	19
300	260	312.1	27

Measure diaphragm for water pipe UNI EN 10224

On request, special version can be supplied.

Standard FULL SCALE with $\Delta P$ max 10000 mmH <sub>2</sub> O										
DN	40	50	65	80	100	125	150	200	250	300
Q. m <sup>3</sup> /h	25	50	80	130	150	300	350	450	800	800
	40	65	100	150	200	420	450	800	1000	1000
H <sub>2</sub> O	55 (*)	90 (*)	140 (*)		280	480 (**)	600	1000	1600	

(\*)  $\Delta P$  max 19000 mmH<sub>2</sub>O

(\*\*)  $\Delta P$  max 13000 mmH<sub>2</sub>O

Quick delivery from stock

### INSTALLATION POSSIBILITIES

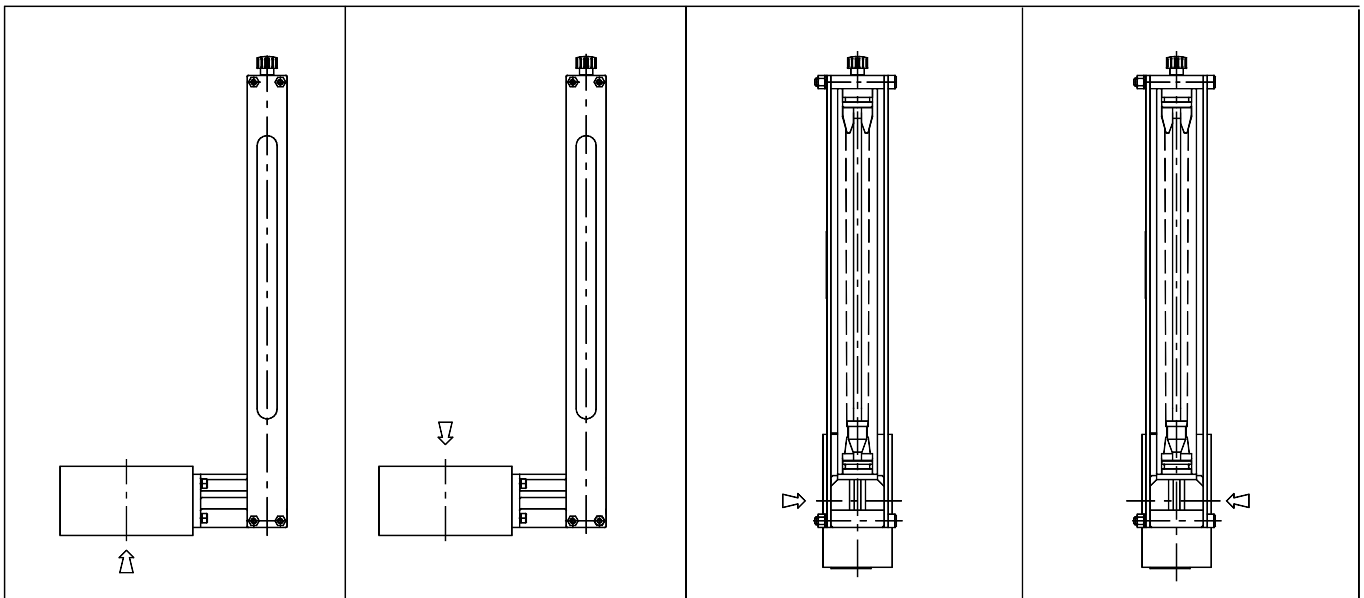

### MATERIALS

Body material: PA6V5010 fino a DN100/ ACC.C + PA6V5010 oltre DN100

Diaphragm: AISI 304

Float: AISI 316

Gasket: NBR

Measuring pipe: Policarbonato

### HOW TO ORDER:

**Example: FBB050P050**

**FBB** Model

**050** DN

**P** Measuring pipe

**050** Flow rate