

# AXIAL EXPANSION JOINTS

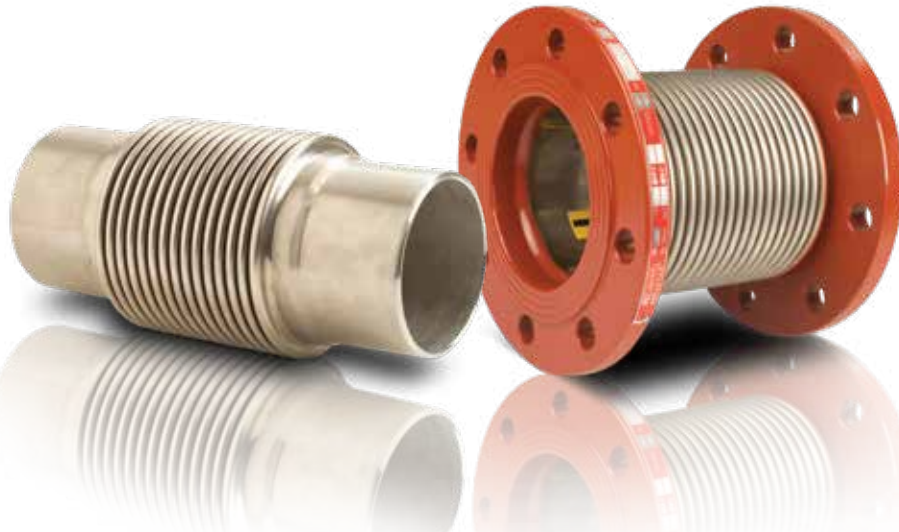

Scan this QR Code



## Advantages of Axial Expansion Joints

- Bellows design according to EJMA coding system.
- Construction according to EN14917 standard.
- Easy to absorb axial movements of the pipelines.
- No direction changes of the flow.
- Minimum application area in comparison with pipe loops.
- Easy installation and maintenance.

## Application Areas

- HVAC piping lines
- Exhaust Systems
- Vibration absorption
- Industrial process & applications

## DESIGN (EN 14917&EJMA)

Bellow Material	Stainless Steel AISI 321 (Opt.304,316L,316Ti,309)
Connection Types	Fixed and Floating Flanged, Welded Ended & Grooved, Threaded
Flange Material	PN 16, St.37.2 as standard, the material can be customised on request
Inner Sleeve	Available in stainless steel AISI 321 (Opt. 304,316L,316Ti,309) on request
Accessories	Inner sleeve, cover, counter flange, gaskets, insulation etc. are available on request.
Certificates	Material certificate 3.1 according to EN 10204 and /or ASME PED 2014/68/EU Cat.III Mod.H

## Operation Conditions

Operating Temperature	-10°C/+550°C
Operating Pressure	Standard pressure rating is PN16 Can be produced with different pressure rates PN 2,5-63 PN corresponds to the allowable operating pressure at room temperature

## Important

Standard models are produced as un-restrained, fixed points should be created as to withstand springing force as well as pressure thrust caused by the system pressure. For detailed information, get in contact with Ayvaz's expert sales team. We strongly advise against the use of expansion joints and bellows for misalignment. Torsion on bellow parts are not desirable and should be eliminated.

## AXIAL EXPANSION JOINTS

### Axial Expansion Joints with 30mm expansion capacity without inner sleeve

With fixed flange			
Type	Expansion Amount	Available Sizes (DN)	Pressure Class (PN)
MKSF-30	30 mm (-20/+10)	25-5000	16

With floating flanges			
Type	Expansion Amount	Available Sizes (DN)	Pressure Class (PN)
MKDF-30	30 mm (-20/+10)	25-5000	16

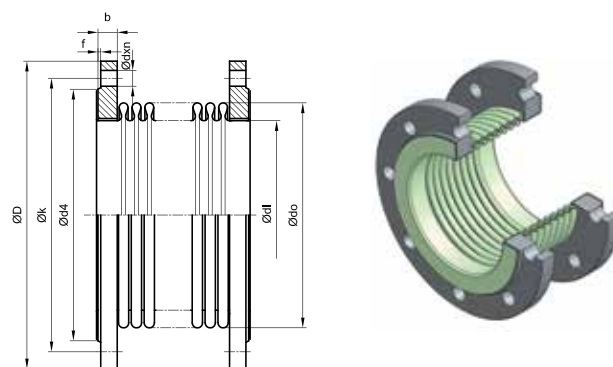
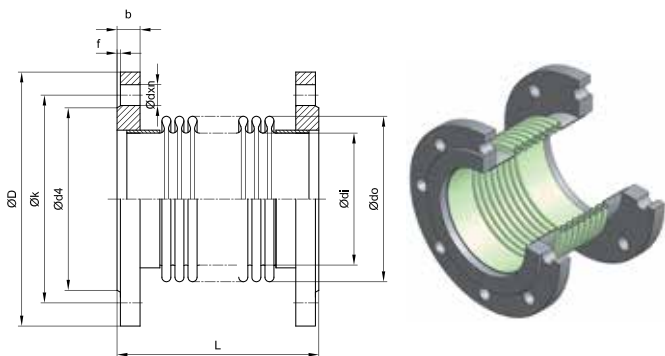

Bellows Information					MKSF-30		MKDF-30	
DN	Ødi	Ødo	Effective Bellows Area cm <sup>2</sup>	Axial Spring Rate N/mm	L	Code	L	Code
DN25	38	48,2	14,58	82,1	120	702.041.101.002	110	702.031.101.002
DN32	42,4	55	18,62	49,7	125	702.041.101.004	115	702.031.101.004
DN40	48,3	61	23,44	60,8	130	702.041.101.006	120	702.031.101.006
DN50	60,3	76	36,46	104,5	120	702.041.101.008	110	702.031.101.008
DN65	76,1	95	57,45	87,8	120	702.041.101.010	110	702.031.101.010
DN80	88,9	111	78,42	178,9	120	702.041.101.012	110	702.031.101.012
DN100	114,3	140	137,09	252,2	130	701.041.101.014	115	701.031.101.014
DN125	139,7	164	181,01	320,0	135	172.041.101.016	130	172.031.101.016
DN150	168,3	200	266,20	196,4	160	702.041.101.018	145	702.031.101.018
DN200	219,1	250	431,86	694,2	160	702.041.101.020	140	702.031.101.020
DN250	273	323	697,11	590,0	170	702.041.101.022	150	702.031.101.022
DN300	323,9	380	972,37	496,8	170	702.031.101.024	150	702.031.101.024

Flange (DIN EN 1092/1) PN 16						
DN	ØD	Øk	Ød4	f	b	Ødxn
DN25	115	85	68	2	16	Ø 14x4
DN32	140	100	78	2	18	Ø 18x4
DN40	150	110	88	3	18	Ø 18x4
DN50	165	125	102	3	20	Ø 18x4
DN65	185	145	122	3	20	Ø 18x4
DN80	200	160	138	3	20	Ø 18x8
DN100	220	180	158	3	22	Ø 18x8
DN125	250	210	188	3	22	Ø 18x8
DN150	285	240	212	3	24	Ø 23x8
DN200	340	295	268	3	26	Ø 23x12
DN250	405	355	320	3	29	Ø 27x12
DN300	460	410	378	4	32	Ø 27x12

Alternative flange dimensions are also possible e.g. according to US standards (ANSI), JIS etc.

\*All dimensions given in the tables are in "mm".

\*\* Subject to technical alterations and deviations resulting from production process without giving any notification.

Reduction Factors for Pressure			
Temperature °C	Reduction Factor Kp	Temperature °C	Reduction Factor Kp
20	1,00	350	0,64
100	0,85	400	0,63
150	0,81	450	0,62
200	0,77	500	0,60
250	0,71	550	0,59
300	0,68	600	0,57

### Pressure reduction factor

The reduction factor is used to define the design pressure [PS] where temperatures exceed 20 °C. It compensates for the decay in material mechanical properties at elevated temperatures. The calculated pressure is lower than the nominal pressure of the standard item.

Calculation:  $PS \leq PN \times Kp$

# AXIAL EXPANSION JOINTS

## Axial Expansion Joint with 30mm expansion capacity with inner sleeve

With fixed flange			
Type	Expansion Amount	Available Sizes (DN)	Pressure Class (PN)
MKSF-30L	30 mm (-20/+10)	25-5000	16

With floating flanges			
Type	Expansion Amount	Available Sizes (DN)	Pressure Class (PN)
MKDF-30L	30 mm (-20/+10)	25-5000	16

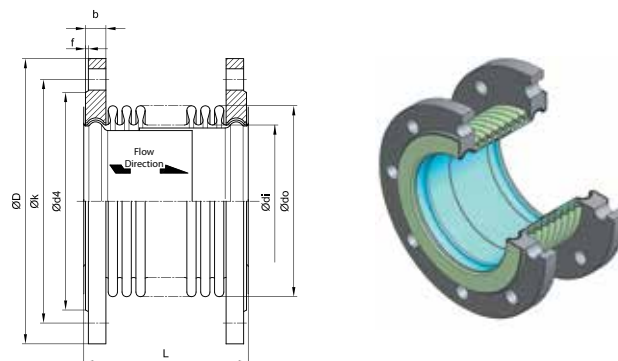
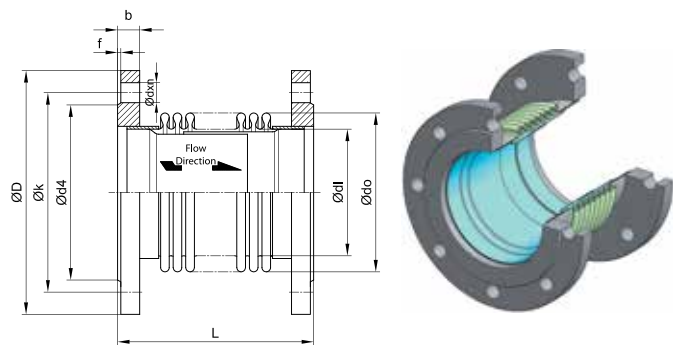

Bellows Information					MKSF-30		MKDF-30	
DN	$\varnothing di$	$\varnothing do$	Effective Bellows Area $cm^2$	Axial Spring Rate $N/mm$	L	Code	L	Code
DN25	38	48,2	14,58	82,1	120	702.041.102.002	110	702.031.102.002
DN32	42,4	55	18,62	49,7	125	702.041.102.004	115	702.031.102.004
DN40	48,3	61	23,44	60,8	130	702.041.102.006	120	702.031.102.006
DN50	60,3	76	36,46	104,5	120	702.041.102.008	110	702.031.102.008
DN65	76,1	95	57,45	87,8	120	702.041.102.010	110	702.031.102.010
DN80	88,9	111	78,42	178,9	120	702.041.102.012	110	702.031.102.012
DN100	114,3	140	137,09	252,2	130	701.041.102.014	115	701.031.102.014
DN125	139,7	164	181,01	320,0	135	172.041.102.016	130	172.031.102.016
DN150	168,3	200	266,20	196,4	160	702.041.102.018	145	702.031.102.018
DN200	219,1	250	431,86	694,2	160	702.041.102.020	140	702.031.102.020
DN250	273	323	697,11	590,0	170	702.041.102.022	150	702.031.102.022
DN300	323,9	380	972,37	496,8	170	702.031.102.024	150	702.031.102.024

Flange (DIN EN 1092/1) PN 16						
DN	$\varnothing D$	$\varnothing k$	$\varnothing d4$	f	b	$\varnothing dxn$
DN25	115	85	68	2	16	$\varnothing 14 \times 4$
DN32	140	100	78	2	18	$\varnothing 18 \times 4$
DN40	150	110	88	3	18	$\varnothing 18 \times 4$
DN50	165	125	102	3	20	$\varnothing 18 \times 4$
DN65	185	145	122	3	20	$\varnothing 18 \times 4$
DN80	200	160	138	3	20	$\varnothing 18 \times 8$
DN100	220	180	158	3	22	$\varnothing 18 \times 8$
DN125	250	210	188	3	22	$\varnothing 18 \times 8$
DN150	285	240	212	3	24	$\varnothing 23 \times 8$
DN200	340	295	268	3	26	$\varnothing 23 \times 12$
DN250	405	355	320	3	29	$\varnothing 27 \times 12$
DN300	460	410	378	4	32	$\varnothing 27 \times 12$

Alternative flange dimensions are also possible e.g. according to US standards (ANSI), JIS etc.

\*All dimensions given in the tables are in "mm".

\*\* Subject to technical alterations and deviations resulting from production process without giving any notification.

Reduction Factors for Pressure			
Temperature $^{\circ}C$	Reduction Factor $K_p$	Temperature $^{\circ}C$	Reduction Factor $K_p$
20	1,00	350	0,64
100	0,85	400	0,63
150	0,81	450	0,62
200	0,77	500	0,60
250	0,71	550	0,59
300	0,68	600	0,57

### Pressure reduction factor

The reduction factor is used to define the design pressure [PS] where temperatures exceed 20  $^{\circ}C$ . It compensates for the decay in material mechanical properties at elevated temperatures. The calculated pressure is lower than the nominal pressure of the standard item.

Calculation:  $PS \leq PN \times K_p$

## AXIAL EXPANSION JOINTS

### Axial Expansion Joint with 60mm expansion capacity with inner sleeve

With fixed flange			
Type	Expansion Amount	Available Sizes (DN)	Pressure Class (PN)
MKSF-60L	60 mm (-40/+20)	25-5000	16

With floating flanges			
Type	Expansion Amount	Available Sizes (DN)	Pressure Class (PN)
MKDF-60L	60 mm (-40/+20)	25-5000	16

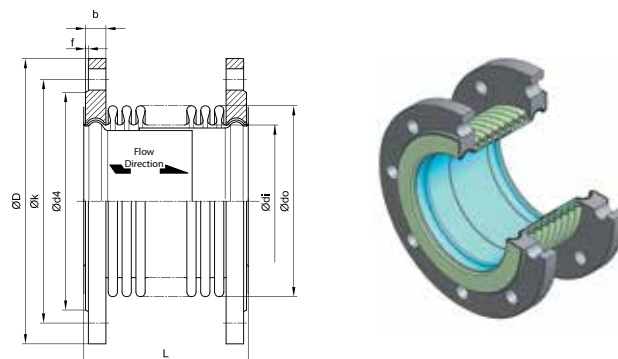
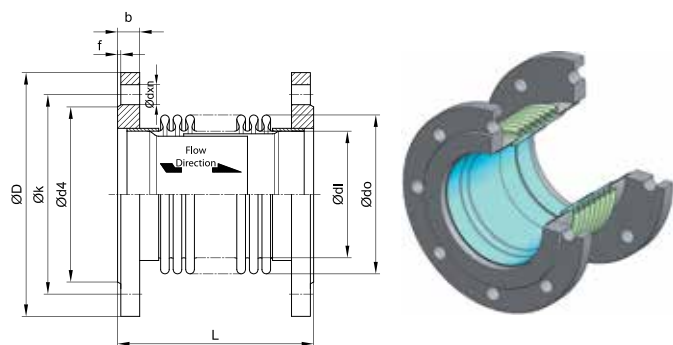

Bellows Information					MKSF-30		MKDF-30	
DN	Ødi	Ødo	Effective Bellows Area cm <sup>2</sup>	Axial Spring Rate N/mm	L	Code	L	Code
DN50	60,3	76	36,46	55,7	200	702.041.202.008	190	702.031.202.008
DN65	76,1	95	57,45	43,9	205	702.041.202.010	195	702.031.202.010
DN80	88,9	111	78,42	89,4	200	702.041.202.012	190	702.031.202.012
DN100	114,3	140	137,09	126,1	215	701.041.202.014	200	701.031.202.014
DN125	139,7	164	181,01	160,0	225	172.041.202.016	210	172.031.202.016
DN150	168,3	200	266,20	98,2	250	702.041.202.018	245	702.031.202.018
DN200	219,1	250	431,86	347,1	265	702.041.202.020	245	702.031.202.020
DN250	273	323	697,11	295,0	270	702.041.202.022	250	702.031.202.022
DN300	323,9	380	972,37	248,4	170	702.031.202.024	250	702.031.202.024
DN200	219,1	250	431,86	694,2	160	702.041.102.020	140	702.031.102.020
DN250	273	323	697,11	590,0	170	702.041.102.022	150	702.031.102.022
DN300	323,9	380	972,37	496,8	170	702.031.102.024	150	702.031.102.024

Flange (DIN EN 1092/1) PN 16						
DN	ØD	Øk	Ød4	f	b	Ødxn
DN25	115	85	68	2	16	Ø 14x4
DN32	140	100	78	2	18	Ø 18x4
DN40	150	110	88	3	18	Ø 18x4
DN50	165	125	102	3	20	Ø 18x4
DN65	185	145	122	3	20	Ø 18x4
DN80	200	160	138	3	20	Ø 18x8
DN100	220	180	158	3	22	Ø 18x8
DN125	250	210	188	3	22	Ø 18x8
DN150	285	240	212	3	24	Ø 23x8
DN200	340	295	268	3	26	Ø 23x12
DN250	405	355	320	3	29	Ø 27x12
DN300	460	410	378	4	32	Ø 27x12

Alternative flange dimensions are also possible e.g. according to US standards (ANSI), JIS etc.

\*All dimensions given in the tables are in "mm".

\*\* Subject to technical alterations and deviations resulting from production process without giving any notification.

Reduction Factors for Pressure			
Temperature °C	Reduction Factor Kp	Temperature °C	Reduction Factor Kp
20	1,00	350	0,64
100	0,85	400	0,63
150	0,81	450	0,62
200	0,77	500	0,60
250	0,71	550	0,59
300	0,68	600	0,57

### Pressure reduction factor

The reduction factor is used to define the design pressure [PS] where temperatures exceed 20 °C. It compensates for the decay in material mechanical properties at elevated temperatures. The calculated pressure is lower than the nominal pressure of the standard item.

Calculation:  $PS \leq PN \times Kp$

# AXIAL EXPANSION JOINTS

## Axial Expansion Joint with Welded Ends

Without inner sleeve			
Type	Expansion Amount	Available Sizes (DN)	Pressure Class (PN)
MKKB-30	30 mm (-20/+10)	25-5000	16

With inner sleeve			
Type	Expansion Amount	Available Sizes (DN)	Pressure Class (PN)
MKKB-30L	30 mm (-20/+10)	25-5000	16
MKKB-60L	60 mm (-40/+20)	25-5000	16

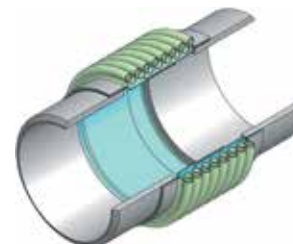
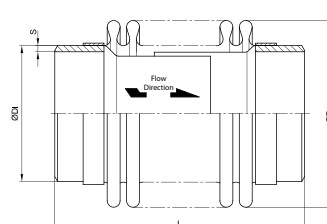
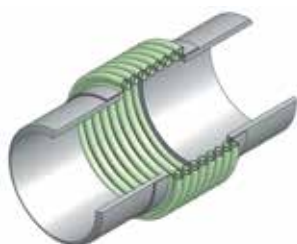
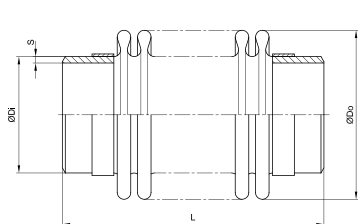

DN	Bellow				S	MKKB-30		MKKB-30L		MKKB-60L	
	ØDi	ØDo	Effective Bellow Area cm <sup>2</sup>	Axial Spring Rate N/mm		L	Code	L	Code	L	Code
DN25	38	48,2	14,58	82,1	2,6	210	702.051.101.006	210	702.051.102.006	N/A	
DN32	42,4	55	18,62	49,7	2,6	215	702.051.101.008	215	702.051.102.008		
DN40	48,3	61	23,44	60,8	2,6	220	702.051.101.010	220	702.051.102.010		
DN50	60,3	76	36,46	104,5	2,9	210	702.051.101.012	210	702.051.102.012	290	702.051.202.012
DN65	76,1	95	57,45	87,8	2,9	210	702.051.101.014	210	702.051.102.014	285	701.051.202.014
DN80	88,9	111	78,42	178,9	3,2	215	702.051.101.016	215	702.051.102.016	300	172.051.202.016
DN100	114,3	140	137,09	252,2	3,6	215	702.051.101.018	215	702.051.102.018	300	702.051.202.018
DN125	139,7	164	181,01	320,0	4,0	220	702.051.101.020	220	702.051.102.020	310	702.051.202.020
DN150	168,3	200	266,20	196,4	4,5	245	702.051.101.022	245	702.051.102.022	345	702.051.202.022
DN200	219,1	250	431,86	694,2	6,3	235	702.051.101.024	235	702.051.102.024	340	702.051.202.024
DN250	273	323	697,11	590,0	6,3	240	702.051.101.026	240	702.051.102.026	340	702.051.202.026
DN300	323,9	380	972,37	496,8	7,1	250	702.051.101.028	250	702.051.102.028	340	702.051.202.028

\*All dimensions given in the tables are in "mm".

\*\* Subject to technical alterations and deviations resulting from production process without giving any notification.

Reduction Factors for Pressure			
Temperature °C	Reduction Factor Kp	Temperature °C	Reduction Factor Kp
20	1,00	350	0,64
100	0,85	400	0,63
150	0,81	450	0,62
200	0,77	500	0,60
250	0,71	550	0,59
300	0,68	600	0,57

### Pressure reduction factor

The reduction factor is used to define the design pressure [PS] where temperatures exceed 20 °C. It compensates for the decay in material mechanical properties at elevated temperatures. The calculated pressure is lower than the nominal pressure of the standard item.

Calculation:  $PS \leq PN \times Kp$