

ALL POSITIONS CAST IRON CHECK VALVE PN16



Size : DN 50 to 300
Ends : Flanges GN10/16
Min Temperature : - 10°C
Max Temperature : + 130°C
Max Pressure : 16 Bars
Specifications : Cast iron disc
All positions
Low head loss

Materials : Cast iron

ALL POSITIONS CAST IRON CHECK VALVE PN16

SPECIFICATIONS :

- All positions
- Respect the flow direction indicated by an arrow on the body
- Flanges GN10/16 up to DN150, GN16 from DN200 to DN300
- Flanges GN10/16 up to DN150, GN16 from DN200 to DN300 with steel strainer basket and 6 mm mesh (Ref. 363)
- Low head loss
- Epoxy painting blue color RAL 5017
- Minimum back pressure for tightness : 0.2 bars

USE :

- Water distribution
- Min Temperature Ts : - 10°C
- Max Temperature Ts :+ 130°C
- Max Pressure Ps : 16 bars

HEAD LOSS GRAPH :

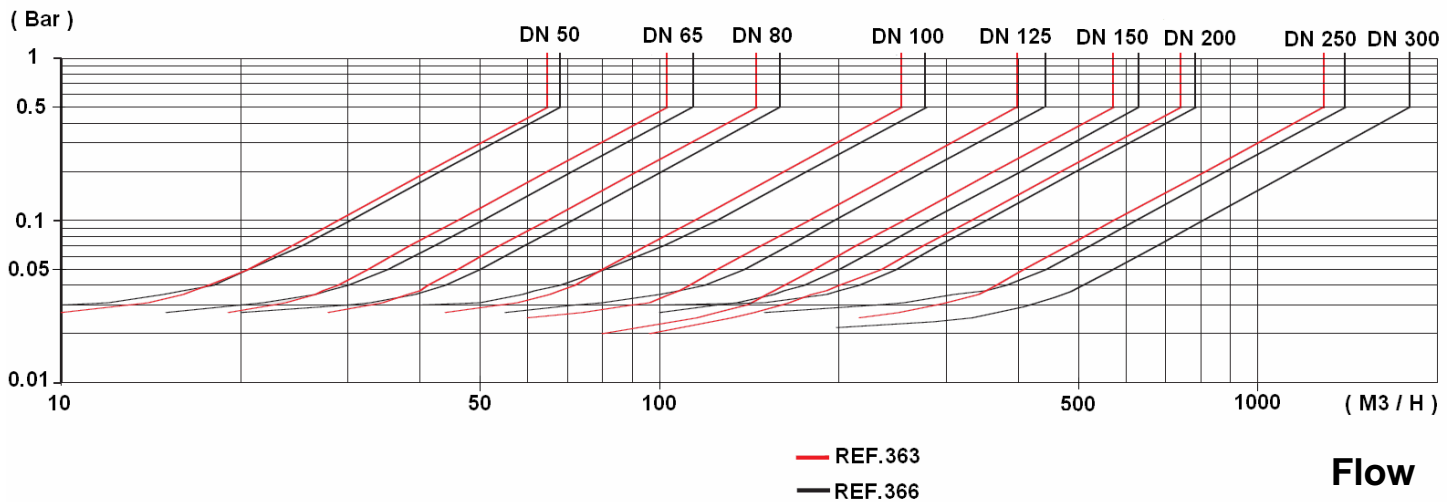

FLOW COEFFICIENT KV (in m3/h) :

REF.	DN	50	65	80	100	125	150	200	250	300
366	Kv (m3/h)	96	160	225	394	620	895	1110	1980	2350
363	Kv (m3/h)	86	143	201	351	553	801	980	1750	2115

RANGE :

- Flanged GN10/16 from DN50 to DN 150 and GN16 from DN 200 to DN 300 **Ref. 366**
- Flanged GN10/16 from DN50 to DN 150 and GN16 from DN 200 to DN 300 with steel strainer basket **Ref. 363**

ALL POSITIONS CAST IRON CHECK VALVE PN16

MATERIALS :

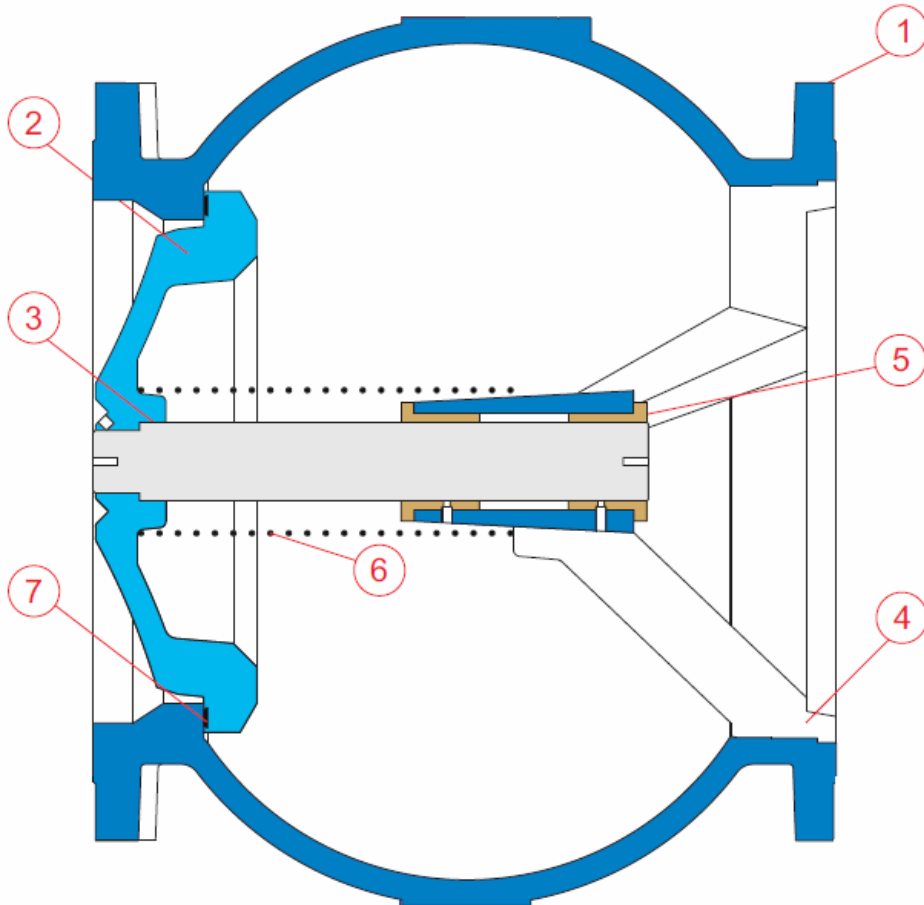

Item	Designation	Materials
1	Body	Cast iron EN-GJL-250
2	Disc	Cast iron EN-GJS-400-15
3	Stem	SS 304
4	Guide	Cast iron EN-GJS-400-15
5	Bushing	Bronze
6	Spring	SS 302
7	Gasket	EPDM

ALL POSITIONS CAST IRON CHECK VALVE PN16

SIZE REF.366 (in mm) :

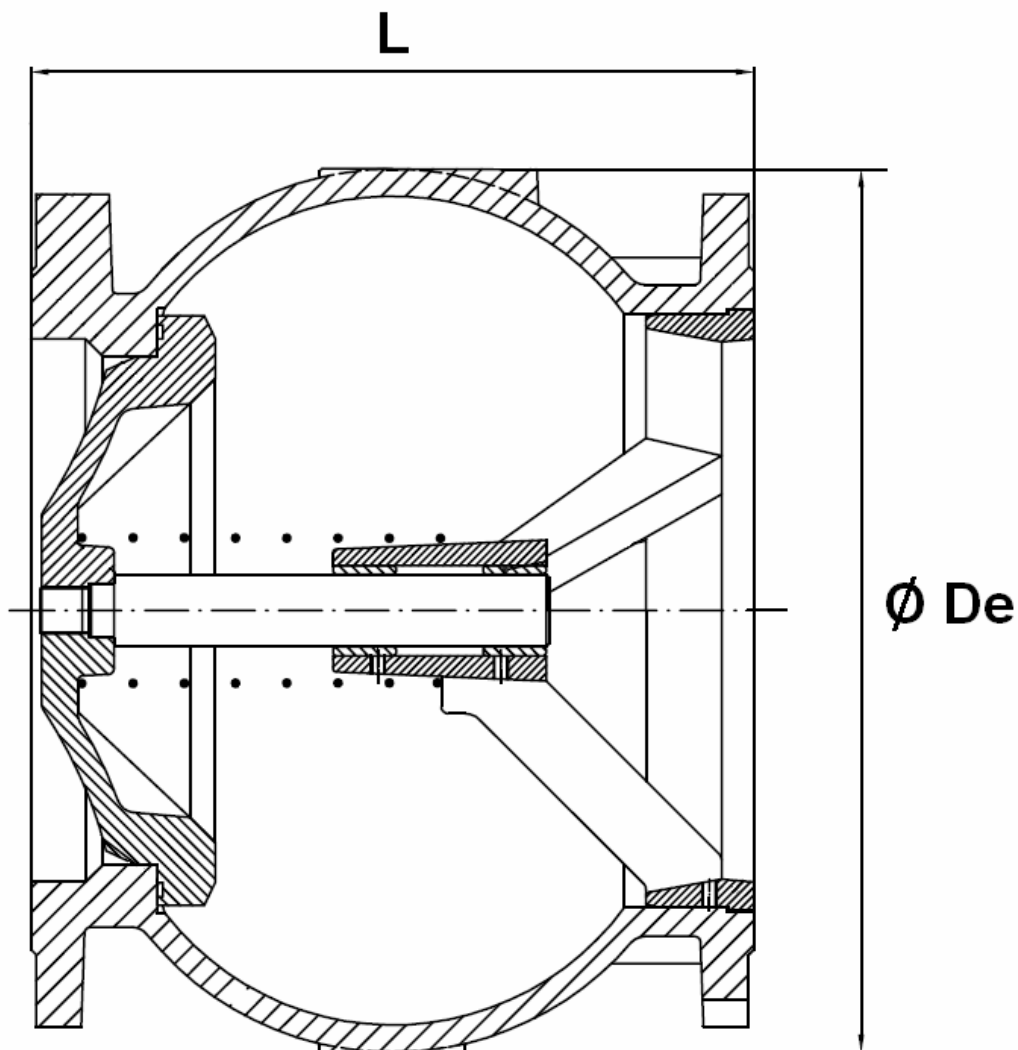

DN	50	65	80	100	125	150	200	250	300
L	100	120	140	165	195	230	290	355	400
De	104	127	157	180	215	250	335	410	486
Weight (Kg)	5.42	8.22	10.13	13.53	19.5	27.07	46.8	77.2	128

ALL POSITIONS CAST IRON CHECK VALVE PN16

SIZE REF.363 (in mm) :

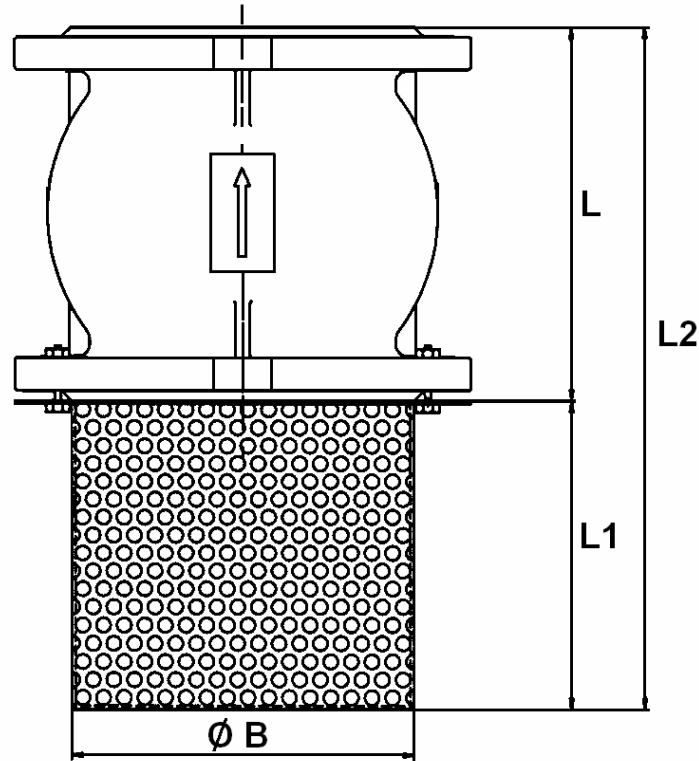

REF.	DN	50	65	80	100	125	150	200	250	300
363	L	100	120	140	165	195	230	290	355	400
	L1	77	110	125	155	170	220	300	390	410
	L2	177	230	265	320	365	450	590	745	810
	Ø B	93	113	128	148	178	200	255	310	360
	Mesh	6	6	6	6	6	6	6	6	6
	Weight (Kg)	6.01	8.98	10.95	14.73	21	28.88	49.58	81.58	133.38

ALL POSITIONS CAST IRON CHECK VALVE PN16

OPENING PRESSURE (mbar) :

DN	Vertical Position Ascending fluid	Vertical Position Descending fluid	Horizontal Position
DN 50	54 ↑	25 ↓	38 →
DN 65	51 ↑	18 ↓	34 →
DN 80	52 ↑	16 ↓	34 →
DN 100	53 ↑	17 ↓	35 →
DN 125	64 ↑	27 ↓	46 →
DN 150	66 ↑	29 ↓	47 →
DN 200	76 ↑	33 ↓	54 →
DN 250	91 ↑	32 ↓	61 →
DN300	94 ↑	30 ↓	62 →

STANDARDS :

- Fabrication according to ISO 9001: 2000
- DIRECTIVE 97/23/CE : Concerned by article 3, § 3
- French water agreement **A.C.S. N° 10 ACC LY 463**
- Tests according to ISO 5208 A category
- Flanges according to EN 1092-1

ADVICE : Our opinion and our advice are not guaranteed and SFERACO shall not be liable for the consequences of damages. The customer must check the right choice of the products with the real service conditions.

ALL POSITIONS CAST IRON CHECK VALVE PN16

INSTALLATION INSTRUCTIONS

GENERAL GUIDELINES :

- Ensure that the check valves to be used are appropriate for the conditions of the installation (type of fluid, pressure and temperature).
- Be sure to have enough valves to be able to isolate the sections of piping as well as the appropriate equipment for maintenance and repair.
- Ensure that the valves to be installed are of correct strength to be able to support the capacity of their usage.

INSTALLATION INSTRUCTIONS :

- **Before installing the check valves, clean and remove any objects from the pipes** (in particular bits of sealing and metal) which could obstruct and block the valves.
- **Ensure that both connecting pipes either side of the check valve (upstream and downstream) are aligned (if they're not, the valves may not work correctly).**
- **Make sure that the two sections of the pipe (upstream and downstream) match, the check valve unit will not absorb any gaps. Any distortions in the pipes may affect the tightness of the connection, the working of the check valve and can even cause a rupture.** To be sure, place the kit in position to ensure the assembling will work.
- **If sections of piping do not have their final support in place, they should be temporarily fixed. This is to avoid unnecessary strain on the check valve.**
- If there is a direction changing or if there's another material, it's better to take away the check valve so that it is outside the turbulence area (**between 3 and 5 times the ND before and after**).
- After a pump please refer to norm NF CR 13932 to install the check valve.