

FLOAT AND THERMOSTATIC STEAM TRAPS FLT17 (1/2" – 1"; DN 15 – 25)

DESCRIPTION

FLT17 float and thermostatic (integral air vent) steam traps series are designed for all types of low and high pressure steam heating and process equipment.

Typical applications include unit heaters, heat exchangers, driers, jacketed vessels and all the applications where continuous drainage is essential.

Connections are female screwed or flanged for horizontal or vertical installation.

MAIN FEATURES

Modulating discharge.

Discharges condensate at steam temperature.

Unaffected by sudden or wide load and pressure changes.

Excellent air discharge (by thermostatic air vent).

OPTIONS: SLR – steam lock release.
Equalizing plug or vent connection.

USE: Saturated and superheated steam.

AVAILABLE MODELS:

FLT17-4,5 , 10 and 14.

SIZES: 1/2" to 1" – DN 15 to DN 25.

CONNECTIONS: Female screwed ISO7/1 Rp (BS21).
Flanged EN 1092-1/-2 PN16 or ANSI.

INSTALLATION: Standard horizontal installation –
From right to left FLT17 (R-L).

Upon request:

-horizontal installation with the flow from left to right (L-R).

-vertical installation with the flow from top to bottom (V).

MAX. DIFFERENTIAL PRESSURE

FLT17-4,5 : 4,5 bar

FLT17-10 : 10 bar

FLT17-14: 14 bar



| CE MARKING – GROUP 2 (PED – European Directive) | |
|---|----------|
| PN16 | Category |
| DN 15 to DN 25 | SEP |

| BODY LIMITING CONDITIONS | | |
|--------------------------|------------------------|---------------------|
| FLANGED PN16 * | FLANGED ANSI 150 lb ** | RELATED TEMPERATURE |
| ALLOW. PRESS. | ALLOW. PRESS. | |
| 16 bar | 15,4 bar | 100 °C |
| 15,5 bar | 14,6 bar | 150 °C |
| 14,7 bar | 13,8 bar | 200 °C |
| 13,9 bar | 12,1 bar | 250 °C |

PMO – Max. operating pressure 14 bar

TMO – Max. operating temperature 198 °C

*Acc. to EN1092-2:2018 ; **Acc. to EN1759-1:2004

Body limiting conditions PN16 or below, depending on the type of connection adopted. PN16 for thread.

| FLOW RATE CAPACITY (kg/h) | | | | | | | | | | | | | | | | | |
|---------------------------|---------|-----------------------------|-----|-----|-----|-----|-----|-----|-----|-----|-----|-----|-----|-----|-----|-----|-----|
| MODEL | SIZE DN | DIFFERENTIAL PRESSURE (bar) | | | | | | | | | | | | | | | |
| | | 0,1 | 0,3 | 0,5 | 0,7 | 1 | 1,5 | 2 | 3 | 4,5 | 6 | 7 | 8 | 9 | 10 | 12 | 14 |
| FLT17-4,5 | 15 – 25 | 165 | 205 | 230 | 280 | 330 | 400 | 440 | 535 | 630 | – | – | – | – | – | – | – |
| FLT17-10 | 15 – 25 | 110 | 130 | 150 | 170 | 200 | 250 | 280 | 340 | 400 | 460 | 495 | 520 | 550 | 595 | – | – |
| FLT17-14 | 15 – 25 | 80 | 100 | 120 | 140 | 150 | 190 | 220 | 260 | 320 | 380 | 400 | 425 | 440 | 480 | 510 | 550 |

| DIMENSIONS (mm) | | | | | | | | | |
|-----------------|---------|-----|----|-----|-----------|------|-----------|-------------|-----------|
| SIZE | Screwed | | | | | PN16 | | ANSI 150 lb | |
| | A | B | C | D | WGT. (kg) | F | WGT. (kg) | F | WGT. (kg) |
| 1/2" – DN 15 | 95 | 178 | 23 | 128 | 5,2 | 150 | 6,7 | 150 | 6,2 |
| 3/4" – DN 20 | 95 | 178 | 23 | 128 | 5,2 | 150 | 7,2 | 150 | 6,4 |
| 1" – DN 25 | 95 | 178 | 23 | 128 | 5,2 | 160 | 7,7 | 160 | 7,3 |

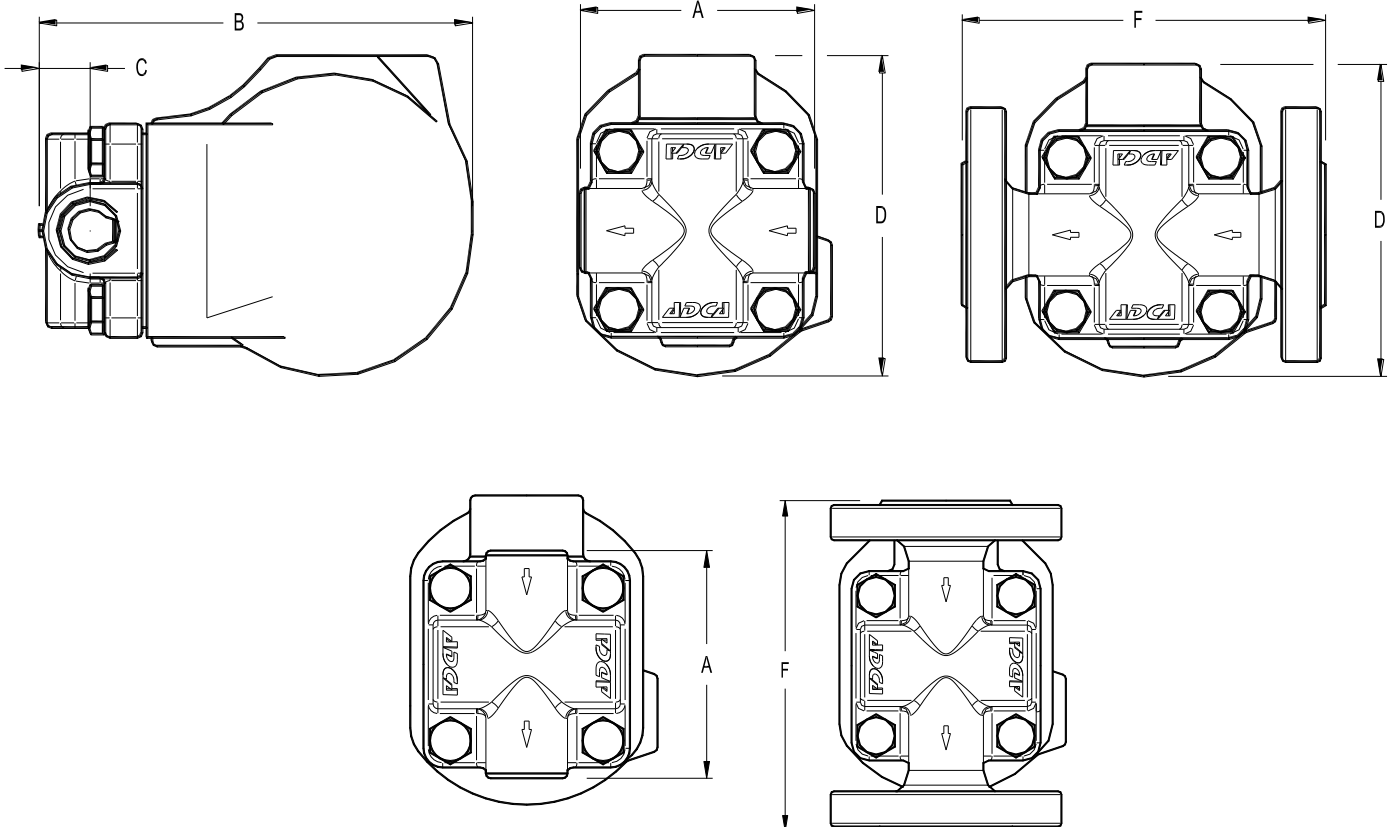

Vertical Installation (V)

| MATERIALS | | |
|-----------|-------------|----------------------------|
| POS. N° | DESIGNATION | MATERIAL |
| 1 | Body | GJS-400-15 / 0.7040 |
| 2 | Cover | GJS-400-15 / 0.7040 |
| 3 | *Gasket | Stainless steel / Graphite |
| 4 | *Seat | AISI 410 / 1.4006 |
| 5 | *Valve | AISI 440C / 1.4125 |
| 6 | *Lever | AISI 304 / 1.4301 |
| 7 | *Float | AISI 304 / 1.4301 |
| 8 | *Air vent | Stainless st. (bimetallic) |
| 9 | Bolts | Steel 8.8 |

* Available spare parts.

